

This document is brought to you by



01371 850537 / info@ohel.co.uk / www.ohel.co.uk

GREASE TRAPS

An effective and hygienic method of separating fat and grease from waste water flow



INTRODUCTION

To help solve the problem of fat and grease removal by using the Klargester Grease Trap.

The Klargester Grease Trap will, by the removal of fat and grease from the waste water flows

- (a) greatly reduce incidents of drain blockages from catering establishments,
- (b) improve the performance of septic tank and land drainage systems,
- (c) prevent the contamination of small sewage treatment plants treating wastes contaminated with fat and grease and thus minimise the associated maintenance and environmental problems.

The unit has been specifically designed for use in the drainage systems of Hotels, Restaurants, Public Houses and Canteens, to remove fat and grease from waste water flows and for a wide range of other applications.

The performance of the design has been assessed and approved by the Danish Ministry of Health, and the product as manufactured in Denmark in concrete, has received German DIN standard approval.

CONSTRUCTION

The trap is manufactured in G.R.P. and can be delivered to site ready to install complete with factory fitted inlet and outlet junctions. A scoop for simple and hygienic fat removal is provided with every unit. Galvanised steel manhole covers and frames are available with the Unit, either to standard pedestrian or heavy duty specifications. Differing inlet drain invert levels can be accommodated by the construction of a brick extension skirt above the base unit, and the manhole covers and frames provided, fitted in the normal way for masonry.

INSTALLATION

In most situations the Grease Trap should be installed on a concrete base slab and surrounded with lean mix concrete. The area around the manhole covers and frames being finished in the conventional manner.

Where extension skirts are being built to increase the invert depth of the unit, it is recommended that Class B Engineering Bricks are used, and that the concrete backfill of the base unit is used to support such brickwork.

Further detailed information regarding dimensions and method of installation are available from Klargester.

OPERATION

The trap should be installed as close to the source of contamination as possible, before any foul waste can enter the drainage flow. In situations where high temperature waste from dishwashers is encountered, the waste should be cooled to a suitable temperature before entering the trap. Cooling of the waste must be carried out to ensure efficient fat and grease removal.

The flow path through the unit and the large surface area available ensure that fat and greasy material are effectively separated. Fat and grease accumulate on the water surface, while waste water passes through to the drainage system.

For the correct size of Grease Trap to suit your application, contact Klargester.

Model No.	Grease Capacity Kgs.	Dimensions (mm)			Weight Kgs Empty/Full
		A Length	B Width	C Height	
2	23	1330	850	1035	50/475
4	45	2070	1200	1335	120/1410

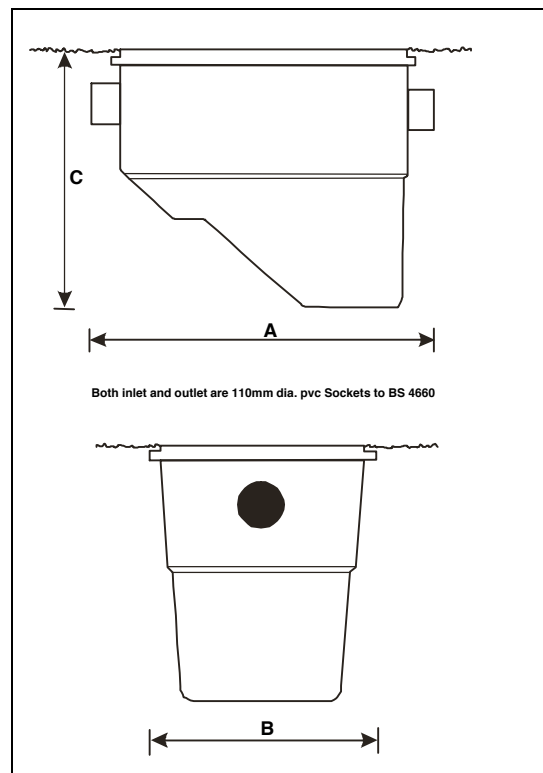

Klargester also manufacture:

Septic Tanks, BioDisc® Sewage Treatment Plants, Cesspools, Pumping Equipment, Fuel/Oil Separators, Silage Effluent Tanks.

Klargester Environmental

College Road North, Aston Clinton, Aylesbury, Bucks., HP22 5EW

Tel: +44 (0) 1296 633000 ~ Fax: +44 (0) 1296 633001

www.klargester.co.uk ~ uksales@klargestere.co.uk

Manufacturing and distribution units also at:

East Kilbride: +44 (0) 1355 248484

Northern Ireland: +44 (0) 28302 66799

ROI: +353 (0) 48 302 66799



